



RDC Charger

User manual



Robotina d.o.o.
OIC-Hrpelje 38 Hrpelje
SI-6240 Kozina
Slovenia

Table of Contents

BM-GW	5
<i>Highlights & Features</i>	5
<i>System specifications</i>	6
<i>HW Technical specification</i>	6
<i>Wiring</i>	9

BM-GW

BTMS IOT Gateway



Order code:	BM-GW-01	NO GSM modem
	BM-GW-02	With GSM modem
Mounting:	DIN rail, 31 mm	
Dimensions:	31 × 125 × 100 mm	

Highlights & Features

- Local WEB UI

- real-time data display
- data logging
- history data display (tables, time-plots)
- history and real-time data download
- e-mail, SMS alarming
- Robust and safe connection of BTMS system to BTMS cloud platform.
- Secure access and communication (TLS encryption)
- Local data buffer, no data loss
- User data safety according to GDPR
- Secure remote access to BM-C controllers

System specifications

- Up to:
 - **32strings arbitrarily distributed on several UPSs**
 - **120 batteries / string** (3840 batteries / system)
 - **Temperature and humidity** sensor for each string
- Logging data for one year by automatically deleting old data
- Send e-mail and SMS alarms directly from the device

HW Technical specification

Power supply:	12 to 24 VDC, 1.39-0.72A	
Construction:	Extruded aluminum and heavy-duty steel, IP30	
CPU:	Intel® Celeron® N3350 2C @1.1 GHz, TDP: 6W	
System Memory:	1 x DDR3L-1866 SO-DIMM 4 GB	
Storage:	128 GB SSD	
System I/O Outlet:	Serial 1 x DB9 RS-232/422/485	
	Display 1 x VGA	
	Ethernet 2 x RJ-45 isolated* 10/100/1000 Mbps	
	DIO 1 x DB9 8-bit programmable DIO	
	LTE Cat 4 Quectel EG25-G Mini PCIe	
Working temp.:	-20°C to +70°C (-4°F to +158°F)	
Humidity:	0% to 95%	
Vibration Endurance:	2 Gms with storage (5 to 500Hz, X/Y/Z direction; random, operating)	
Mounting:	DIN rail, wall	
Weight (net/gross):	0.3 kg (0.67 lb)/0.45 kg (0.99 lb)	
Dimensions:	height	125 mm
	width	31 mm
	depth	100 mm

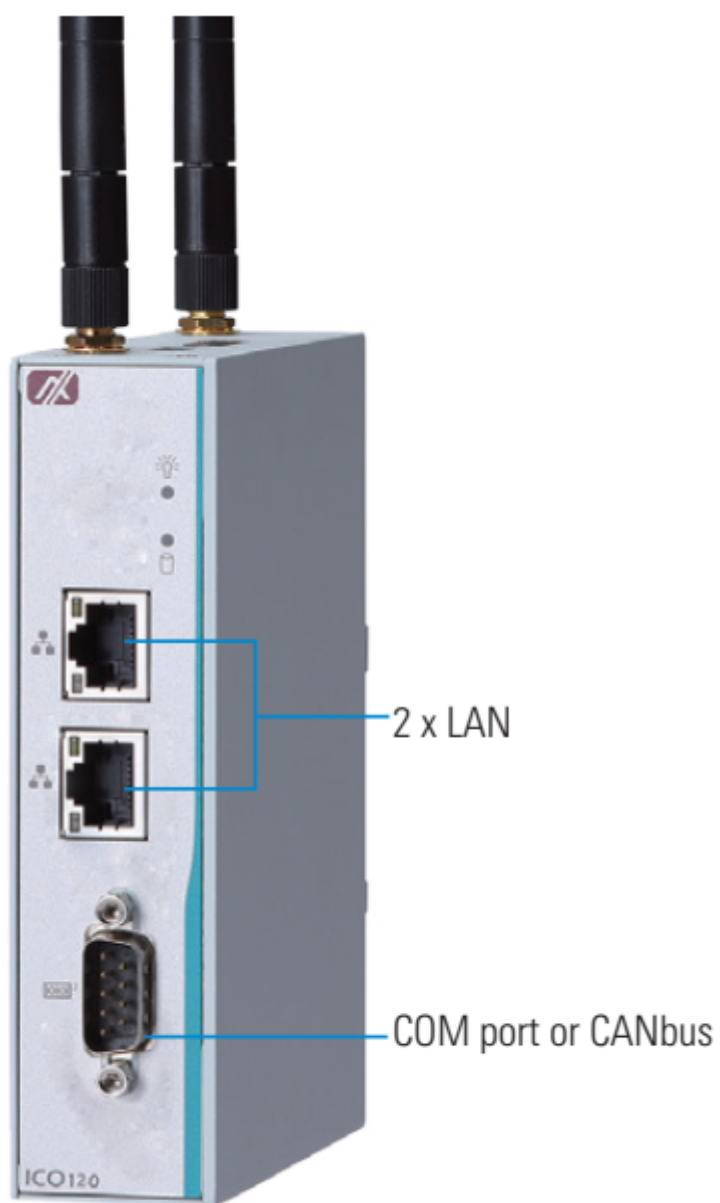

▲ Front view



▲ Rear view



2 x USB



1 x DI/DO
(8-bit programmable)

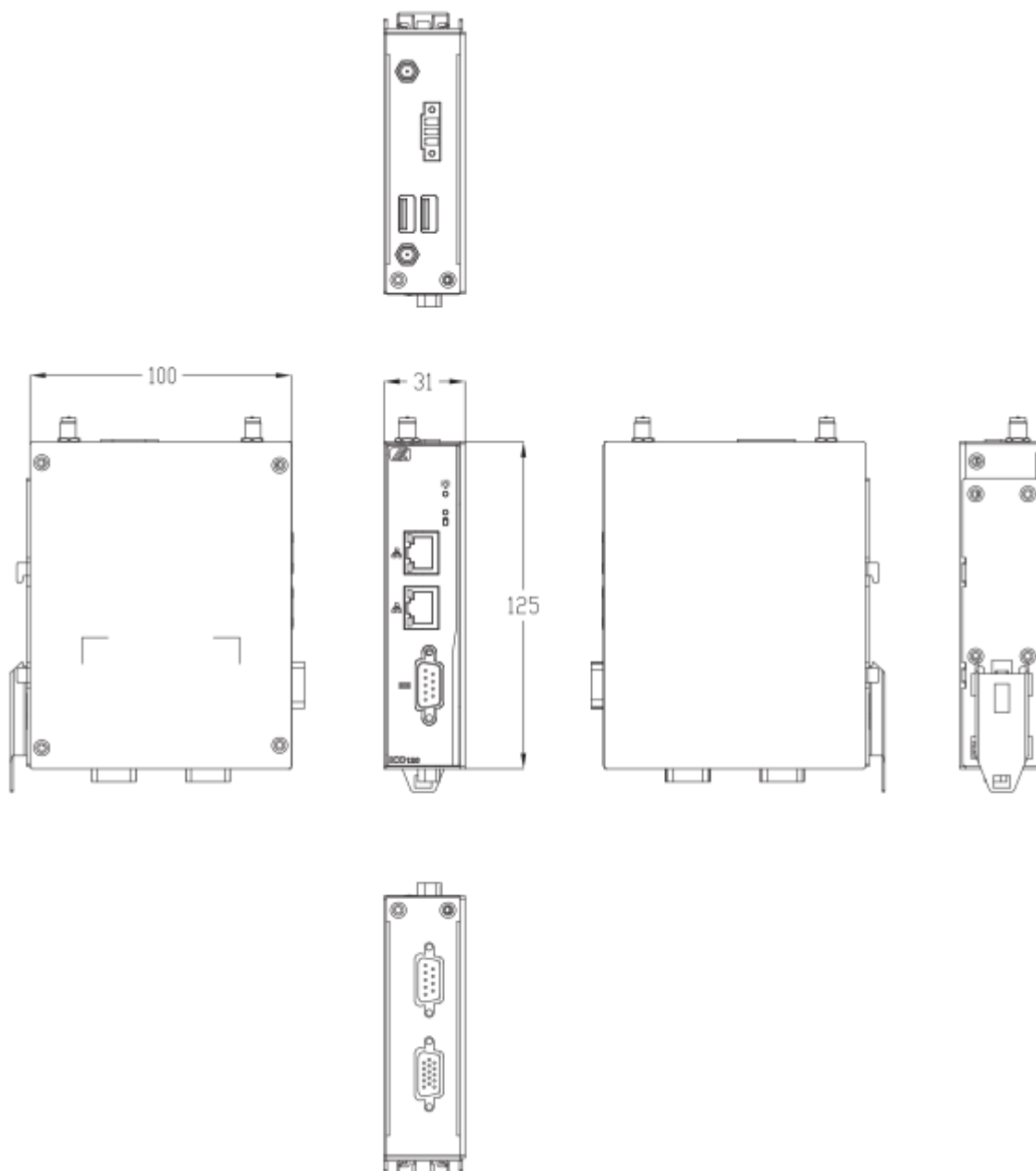

Wiring

