

WR-5

Wireless Modbus relay

Model number:	WR-5
---------------	-------------



Features

- wireless fan-coil controller
- 5 remote controlled relays
- 1 temperature sensor input
- 1 digital input, dry contact
- modbus RTU slave protocol
- very long range, no hopping
- up to 16 devices per group
- multiple addressable groups
- protected private connection

Technical specification

MODBUS

Address range:	220..235
Data bits & parity:	8n1

Supported functions:	01 – read coils
	04 – read input registers
	05 – write single coil
	15 – write multiple coils

RADIO

Frequency band:	ISM 868MHz (EU)
Subband:	L 866.8MHz, 25mW, 1% utility
Modulation	FSK 38.4kbps 80kHz bandwidth
Group address	32-bit, automatically generated
Listen before talk	yes, delay limited to 20ms
Startup time	10s power-on to network ready
Message delay	5ms from tx start to relay on
Operating range	300m with optical visibility
Output power	25mW

GENERAL

Power supply	230V, 50..60Hz, 3.5W
Terminals	0.25..2.5mm ²
Operating conditions	-20..+50°C, 0..85% rh nc
Storage temperature	-40..+85°C
Weight	220g
Degree of protection	IP20
Standards	EN60730-1, EN300-220-2, EN 301 489-1, EN 301 489-3

Dimensions and mounting

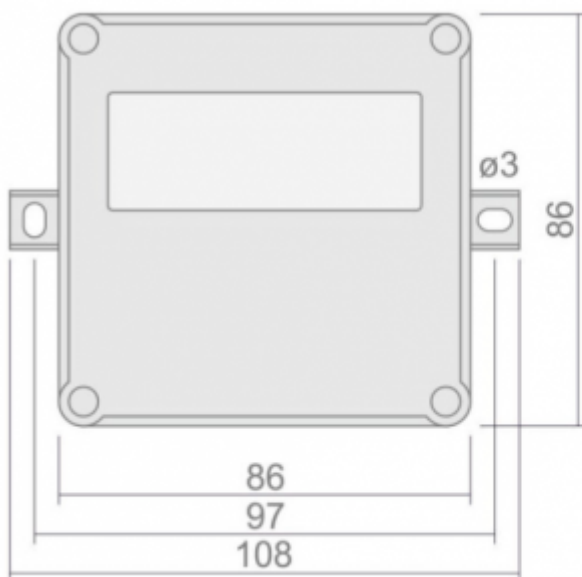

Device should not be installed inside the metal cabinet. Distance from antenna to the nearest object should be at least 10cm.

Terminals

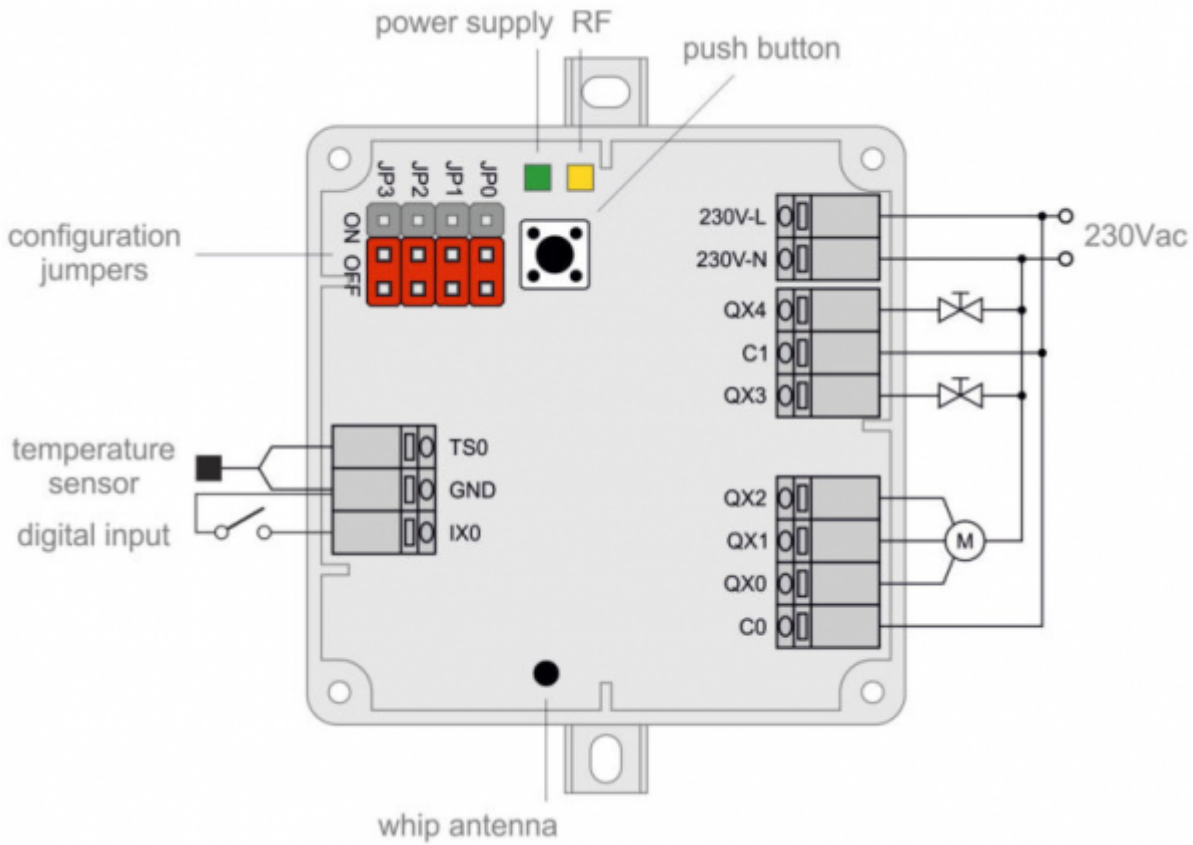

Examples



Cybro-3-RFM, as modbus master, can directly control WR-5 devices.



Any modbus master, using WM-1 bridge, can control WR-5 devices.