



# RDC Charger

## User manual



**Robotina d.o.o.**  
OIC-Hrpelje 38 Hrpelje  
SI-6240 Kozina  
Slovenia



# Table of Contents

<b>PM1-E-D-CT</b> .....	5
<b>Applications</b> .....	5
<b>Features</b> .....	5
<b>General description</b> .....	6
<b>Technical specifications</b> .....	6
<b>Terminals</b> .....	7
<b>Dimensions</b> .....	8
<b>Downloads</b> .....	8



# PM1-E-D-CT

## 1-phase power-sensor, current transformer



Model number:	<b>PM1-E-D-CT</b>
Connect to:	RS485 power sensor bus A - B
Mounting:	DIN rail, 1M, 18 mm
<b>Used for measuring power and energy of</b>	
✓	single-phase energy sources
✓	single-phase energy consumers

## Applications

- Digital multi-function power sensor for single phase networks

## Features

- DIN rail mounting with 50A current transformer ([1-ph current transformer](#))
- Compact design in a single module 18mm wide
- Seal-able cover(phase and neutral terminals)

## General description

The PM1-E-D-CT series is an advanced single phase energy monitoring solution with built-in configuration push button and LCD data display. Particularly indicated for metering active energy and other power parameters. Housing for DIN-rail mounting, IP51 protection degree.

## Technical specifications

<b>Technical Data</b>	
Operating Humidity	≤ 75%
Storage Humidity	≤ 95%
Operating Temperature	-20°C - +50°C
Storage Temperature	-30°C - +70°C
International Standard	IEC 62053-21
Accuracy	Class 1
Mounting	DIN rail (DIN 43880)
Sealing	IP51 Indoor
Nominal Voltage Input	(Ph+N) 230V AC (176-276V AC)
Max Continuous Voltage	120% of nominal
AC Voltage Withstand	4KV for 1 minute
Impulse Voltage Withstand	6KV-1.2μS
Current Input	0.25-5A(6)A AC RMS
Operational Current Range	0.4% Ib-I <sub>max</sub>
Over current withstand	20I <sub>max</sub> for 0.01s
Nominal Input Current Burden	0.5VA
Frequency	50Hz(±10%)
Power Consumption	≤ 2W/10VA/phase
<b>Accuracy</b>	
Voltage, Current	0.5%
Frequency	0.2% of Mid-Frequency
Power Factor	1% of Unity (0.01)
Active Power, Apparent Power	≤ 1% of Range Maximum
Reactive Power	≤ 1% of Range Maximum
Reactive Energy (Varh)	Class 2
Active Energy (Wh)	Class 1
<b>Current transformer</b>	
Frequency	50-60 Hz
Rated current	50 A
Accuracy	from 20% to 120% of rated current
Phase angle	less than 2 degrees at 50% of rated current
Insulation voltage	600 VAC
Maximum primary voltage	5000 VAC (insulated conductor)
Dielectric strength	2.5 kV/1mA/1min
Operating temperature	-15 to 60°C
Operating humidity	< 85 %

Case material	PC/UL94-V0
Bobin	PBT
Core	Permalloy
Internal structure	Epoxy
Leads	UL 1015, Twisted pair, 22 AWG
<b>Modbus</b>	
Bus Type	RS485 (Semi-Duplex)
Protocol	Modbus RTU
Baud Rate	1200/2400/4800/9600bps
Address Range	1-247
Max. Bus Loading	64pcs
Communication Distance	1000 Meters
Parity	EVEN/ODD/NONE
Data Bit	8
Stop Bit	1

## Terminals

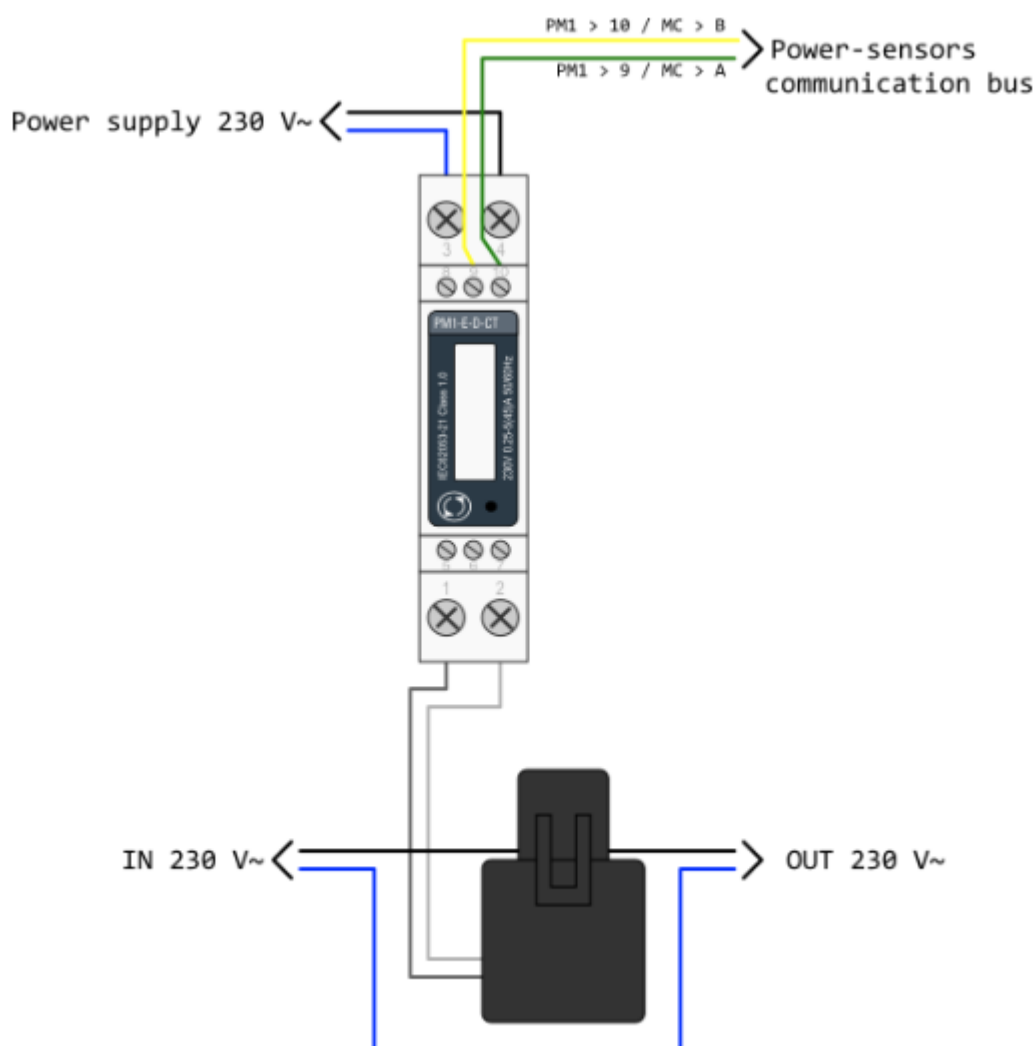

## Dimensions

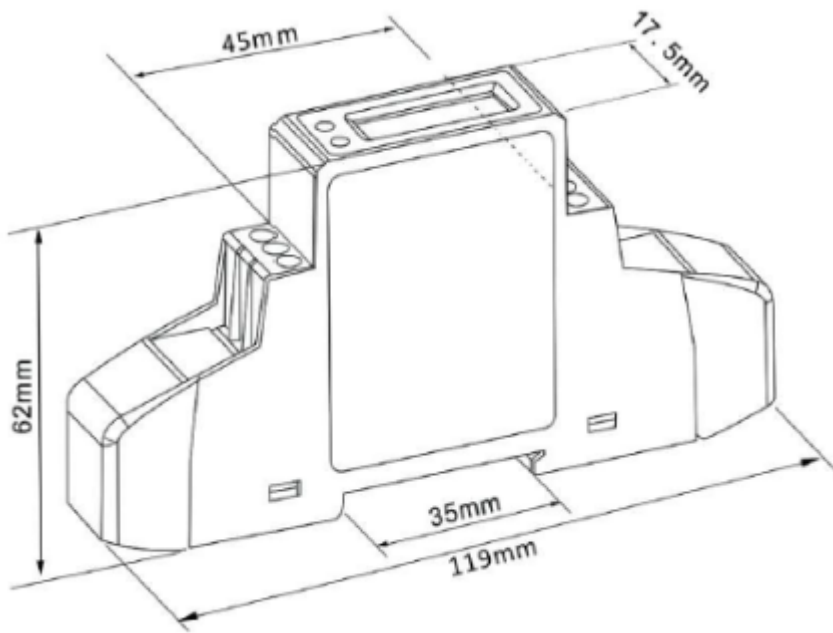

## Downloads

[hiq\\_pm1-e-d-ct\\_user\\_manual\\_2020\\_v1.0.pdf](#)  
[hiq\\_pm1-e-d-ct\\_protocol\\_v1.2.pdf](#)