

# PM1-E-D

## Single phase power-sensor



Model number:	<b>PM1-E-D</b>
	RS485 power sensor bus A - B
Mounting:	DIN rail, 1M
<b>Used for measuring power and energy of</b>	
✓	single-phase energy sources
✓	single-phase energy consumers

## Applications

- Digital multi-function power-sensor for single phase networks

## Features

- DIN rail mounting with direct connection up to 45A
- Compact design in a single module 18mm wide
- Seal-able cover(phase and neutral terminals)

## General description

The PM1-E-D series is an advanced single phase energy monitoring solution with built-in configuration push button and LCD data display. Particularly indicated for metering active energy and other power parameters. Housing for DIN-rail mounting, IP51 protection degree, direct connection up to max 45A.

## Technical specifications

<b>Energy Measurements</b>	
Imported/Exported active energy	0 to 99999.99 kWh
Imported/Exported reactive energy	0 to 99999.99 kVArh
Total active energy	0 to 99999.99 kWh
Total reactive energy	0 to 99999.99 kVArh
<b>Measured Inputs</b>	
Nominal Voltage Input	(Ph+N) 176 to 276V
Max Continuous Voltage	120% of nominal
Nominal Input Current	5(45)A
Max Continuous Current	120% of nominal
Frequency	50Hz (±10%)
<b>Accuracy</b>	
Voltage	0.5% of range maximum
Current	0.5% of nominal
Frequency	0.2% of mid-frequency
Power factor	1% of unity (0.01)
Active power (W)	±1% of range maximum
Reactive power (VAr)	±1% of range maximum
Apparent power (VA)	±1% of range maximum
Active energy (Wh)	Class 1 IEC 62053-21
Reactive energy (VARh)	±1% of range maximum
<b>Modbus (RS485 Output for Modbus RTU &amp; Pulsed Output)</b>	
Baud rate	1200, 2400, 4800, 9600.
Parity	none / odd / even
Stop bits	1 or 2
RS485 network address	1 to 247
<b>Reference Conditions of Influence Quantities</b>	
Ambient temperature	23°C ±1°C
Input waveform	50 or 60Hz ±2%
Input waveform	Sinusoidal (distortion factor < 0.005)
Auxiliary supply voltage	Nominal ±1%
Auxiliary supply frequency	Nominal ±1%
Auxiliary supply waveform (if AC)	Sinusoidal (distortion factor < 0.05)
Magnetic field of external origin	Terrestrial flux
<b>Environment</b>	
Operating temperature	-25°C to +55°C
Storage temperature	-40°C to +70°C
Relative humidity	0 to 95%, non-condensing
Altitude	Up to 3000m
Warm up time	1 minute
Vibration	10Hz to 50Hz, IEC 60068-2-6, 2g
Shock	30g in 3 planes
<b>Mechanics</b>	
DIN rail dimensions	18mm x 90mm (WxH) per DIN 43880

## Terminals

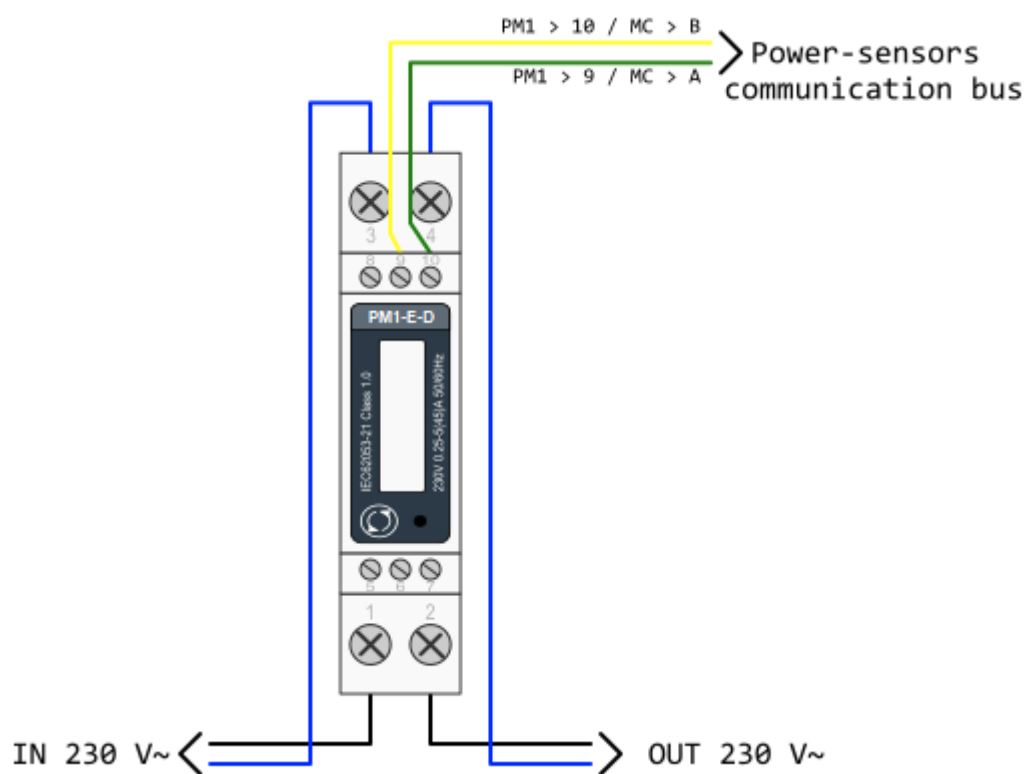

## Dimensions

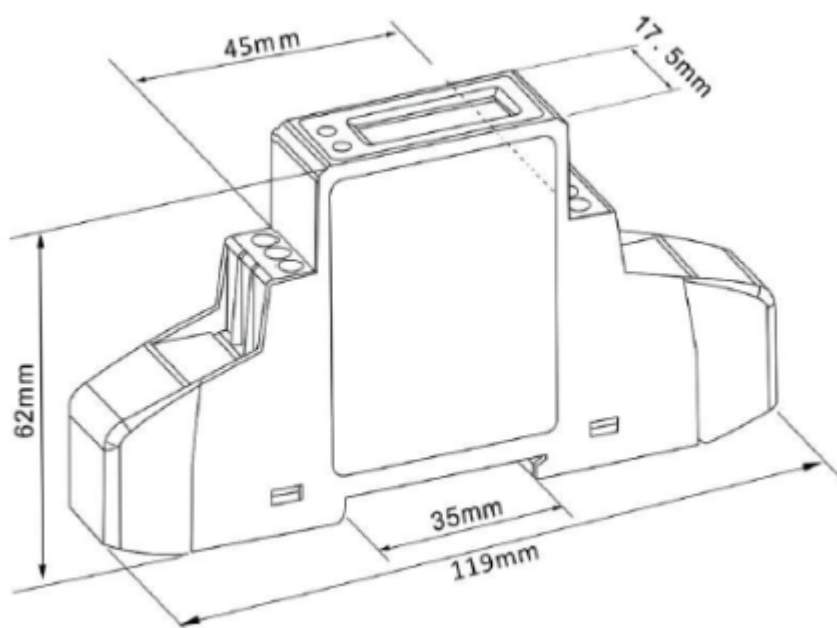

---

## Download

[hiq\\_pm1-e-d\\_user\\_manual\\_2020.pdf](#) [hiq\\_pm1-e-d-modbus\\_protocol\\_v2.2.pdf](#)