

WR-1

Wireless Modbus Relay





Model number:	WR-1
Frequency:	ISM 868MHz (EU)
Dimensions:	93x45x27 mm

Applications

- Remote controlled relay. Act as modbus RTU slave. Optimal for long range, no hopping.

Installation and mounting

-  Carefully open WR-1 module and configure address with jumpers. (Default address is 200)
-  Place WR-1 module at least 10cm from other objects. Installation is not recommended inside metal cabinets.

- Connect relay terminals
- Connect to 230V power supply
- Configure radio pairing

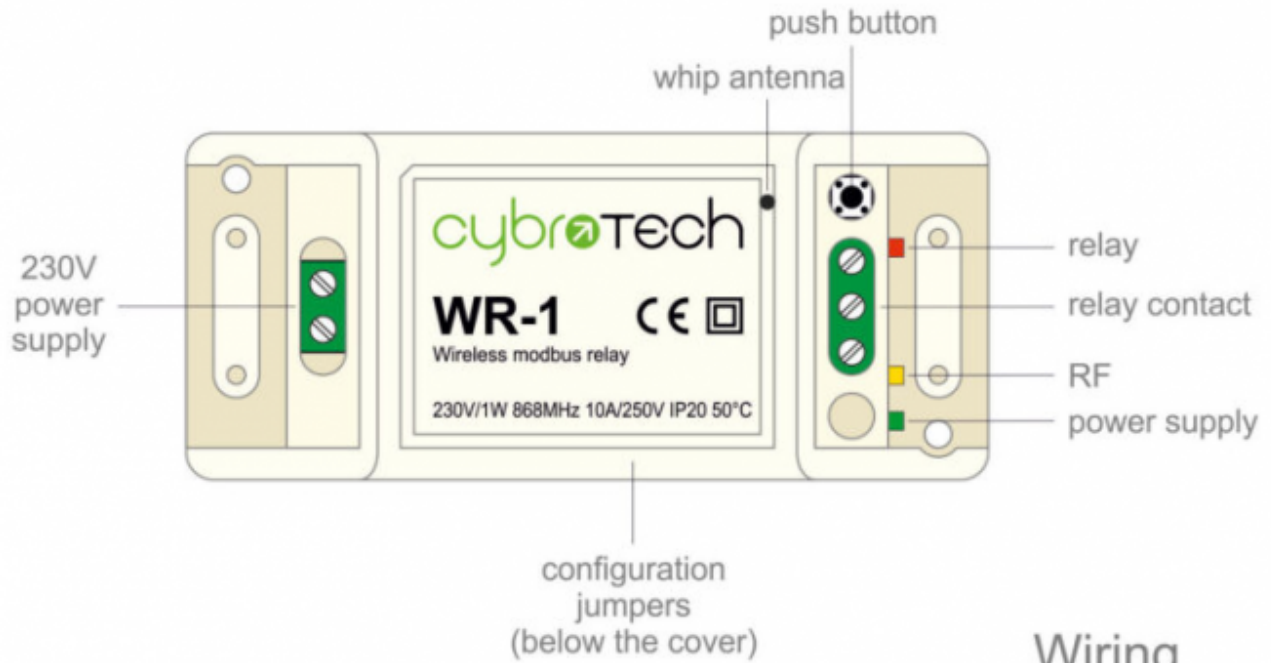

Wiring

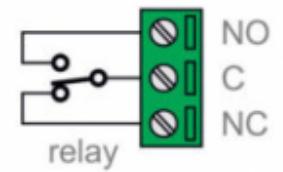

Features

- remote controlled relay
- act as modbus RTU slave
- very long range, no hopping
- up to 8 relays per network
- protected private connection
- multiple addressable groups

Technical specification

Power supply:	230V, 50/60Hz, 1W
Ingress protection:	IP20
Operating temperature:	-20..50°C
Storage temperature:	-40..85°C
Relative humidity:	0..85% n/c

Modbus

Address range:	200..207
Relay mapping	coil 1(start address 00h)
Data bits & parity	8n1
Supported functions	01 - read coil 05 - write single coil 15 - write multiple coils

Relay output

Nominal rating	10A 250Vac (NO), 3A 250Vac (NC)
(resistive)	5A 30Vdc (NO), 3A 30Vdc (NC)

Radio

Frequency band	ISM 868MHz (EU)
Subband	L 866.8MHz, 25mW, 1% utility
Modulation	fSK 38.4kbps 80kHz bandwidth
Listen before talk	yes, delay limited to 20ms
Group address	32-bit, automatically generated
Connection time	10s power-on to network ready
Message delay	5ms from tx start to relay on
Output power	25mW
Operating range	3..300m with optical visibility

Modbus address setting

Change is applied right away, no reset needed.

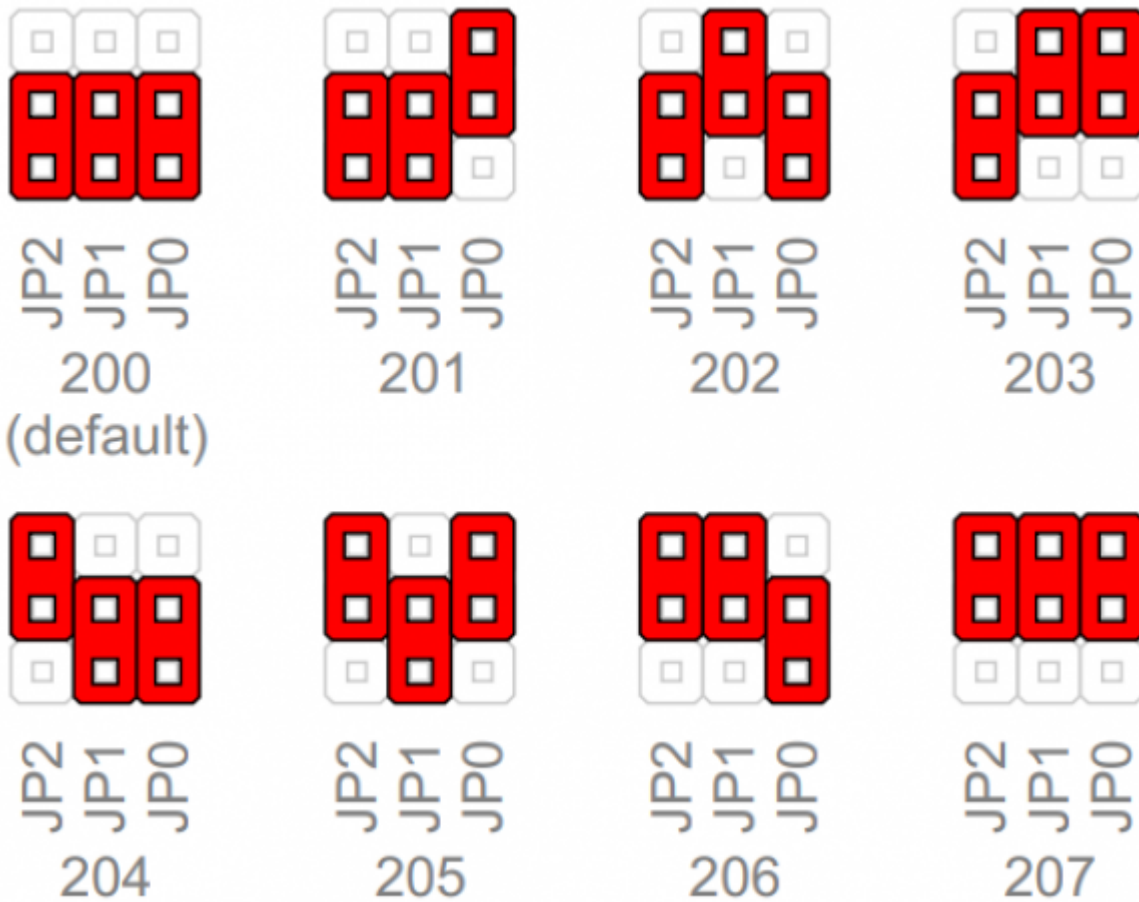

Radio pairing configuration

Create new secure group

- * turn on all devices as the same time
- * within 10 seconds, while RF LED is blinking, press and hold button on one of the devices
- * after a second, the new address is randomly generated and sent to all devices. RF LED will blink 3 times to confirm the new address.

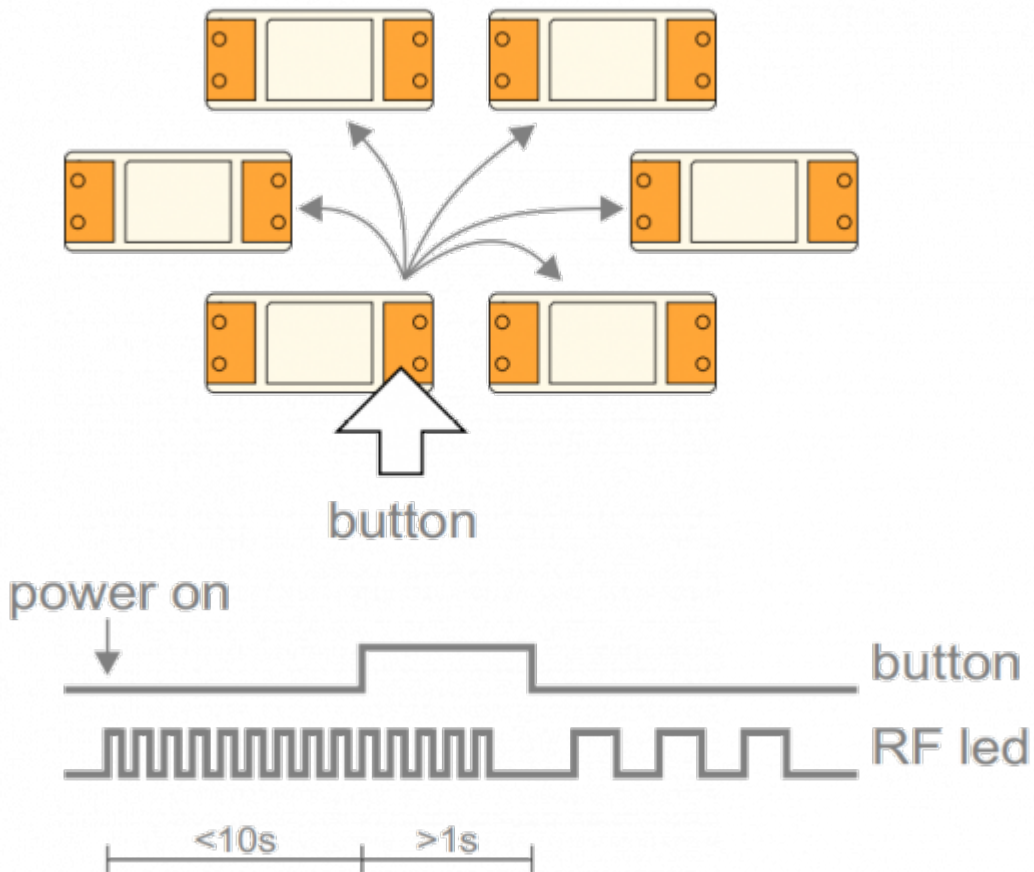

Add new device to the group

- * turn on the device
- * within 10 seconds, press and hold button on one of the existing devices
- * after a second, the existing group address is sent to the new device. RF LED will blink 3 times to confirm the address is sent.

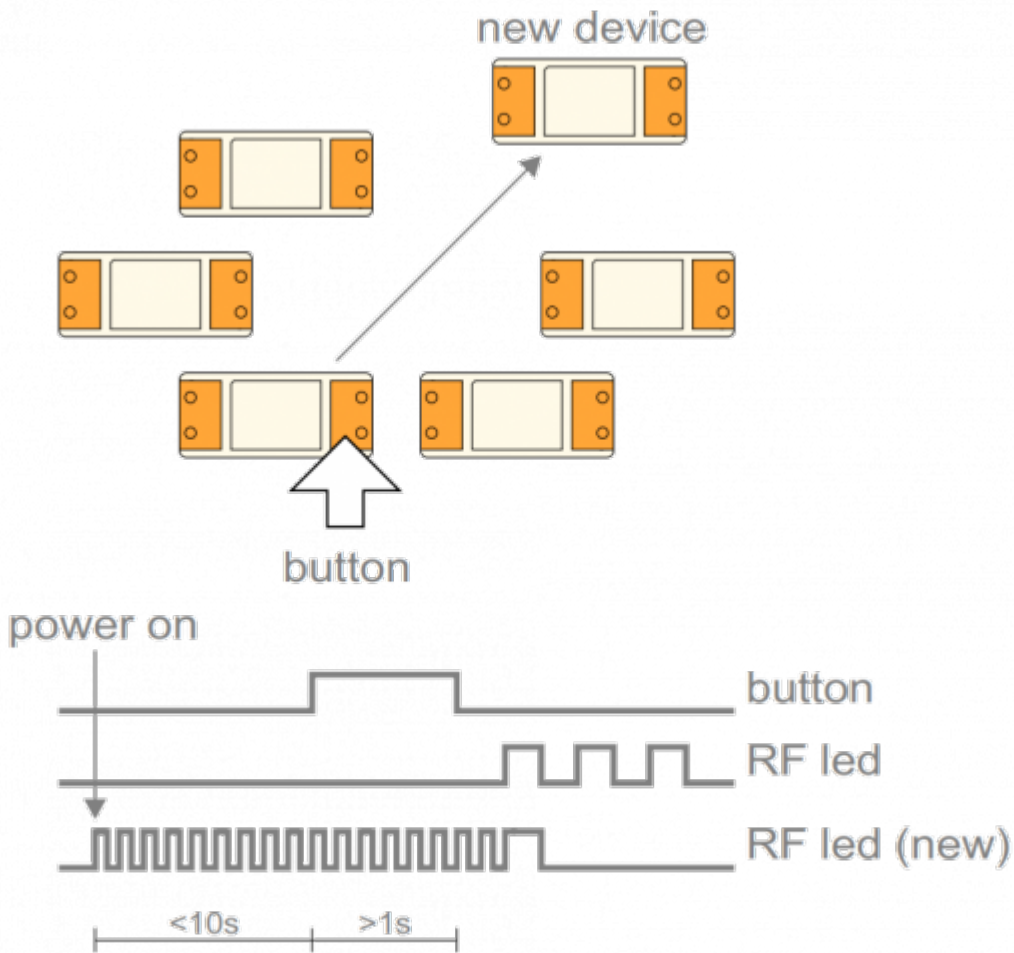

Examples

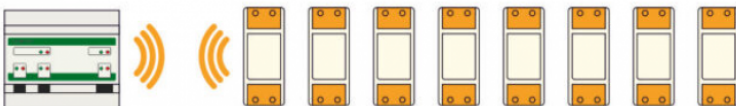

Cybro-3-RFM, acting as modbus master, connected to 8 wireless relays (200..207).

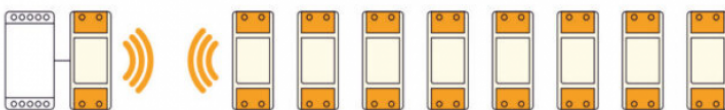

Any modbus master, connected to 8 relays using WM-1 device as wireless adapter.

Connection check

- press the button shortly

With each press of the button, the relay will switch on/off. Other devices are not affected.



Factory reset

- Hold button and turn the device ON
- RF led will blink twice. Group address is now reset to default.
- Other devices will not be affected.

