

LC-DC2-ISO

IEX-2 module, DALI-2 application controller



Model number:	LC-DC2-ISO
Mounting:	DIN rail

Features

- IEX-2 module
- DALI-2 application controller
- DALI-2 multi-master
- send and receive DALI power supply
- 10 digital inputs
- galvanic isolation

Technical specification

DALI output current	200mA
Ballasts per device	64 (2mA per device)
Bus length	300m
Galvanic isolation	3kV, DALI to digital ground
Surge protection	4kW (8/20us), 30kV/150pF
Autoaddress	no
Typical usage	office buildings and halls
Duty cycle	1:10 (DALI active 10% of the time)
Load protection	short-circuit and thermal shutdown
230V tolerance	no
Input type	dry contact, internal pull-up 12V 2mA
Power supply	24V (18..28V), 200mA
Operating conditions	0..45°C, 0..95% rh non-condensing
Storage temperature	-20..75°C
Degree of protection	IP20
Weight	120g
Standards	EN 60730-1, EN 61000-4-4

Terminals

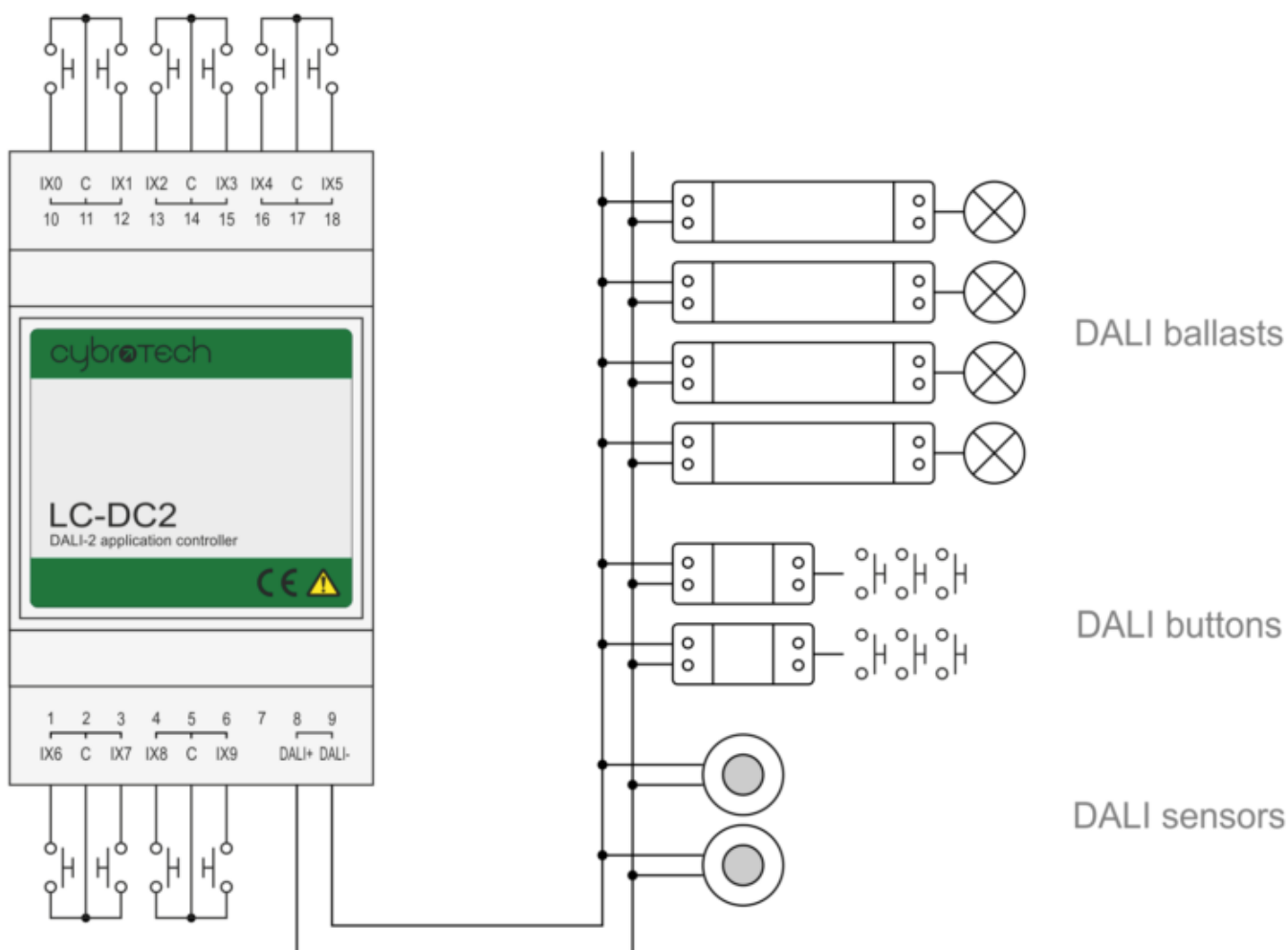

Dimensions

