

LC-DC2

Voltage inputs, 12 x 0...10V



Model number:	LC-DC2
Mounting:	DIN rail

Features

- IEX-2 module
- DALI-2 application controller
- DALI-2 multi-master
- send and receive DALI power supply
- 10 digital inputs

Technical specification

Input type	0..10V
Input resistance	10K
A/D converter	V/f conversion with auto calibration
Resolution	13 bits in 0.1% mode 11 bits in 0.5% and 1% mode
Temperature drift	+/-0.01%/°C of measuring range
Scan time	30ms..980ms, depends on input mode
Integration time	60ms/20ms, depends on input mode
Calibration reference	10.000V
Power supply	24V (18..28V), 50mA
Galvanic isolation	1kV between digital and analog circuit no isolation between chanel
Operating conditions	0..50°C, 0..85% rh non-condensing
Weight	160g
Degree of protection	IP20
Level of ambient pollution	2
Standards	EN 61010-1, EN 61010-2-201, EN 61131-2

Terminals

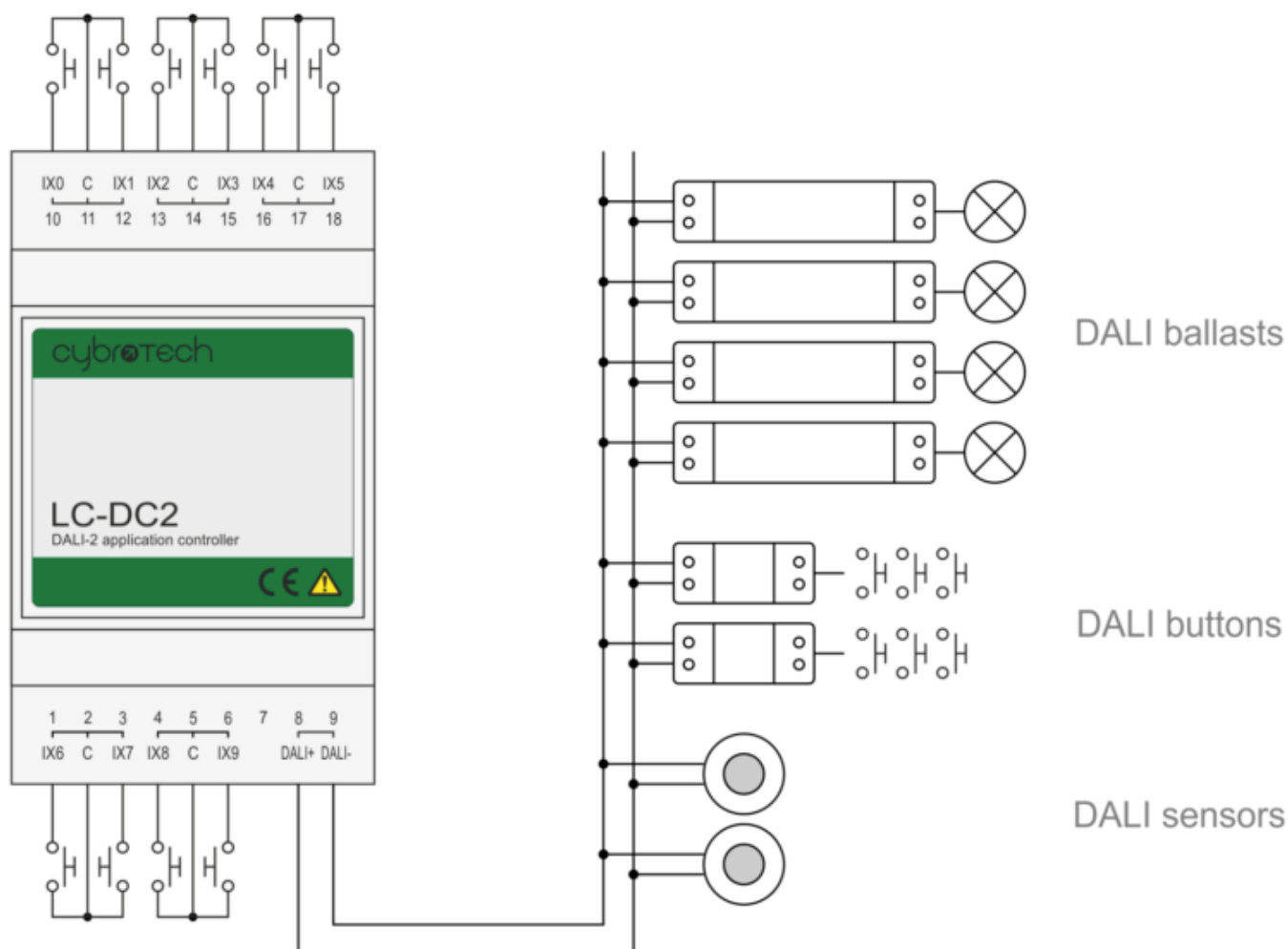

Dimensions

